

Contents

Introduction	3
Curriculum Links	4
Resources Table	5

Term 1

Space travel	Page
Fact File	7
Understanding the Basics	8
Straw Rocket	10
Balloon Rockets	13
Fizz Pop Rockets	17
'Toobz' Satellites	20
K'Nex Space Shuttles	22

Term 2

Wheels in Motion	Page
K'Nex Moon Buggy	24
Basic Buggy	25
'Toobz' Grandstand	27
Elastic Band Power	28
Wind Power	30
Buggy Challenge	32

Term 3

Fire Safe Bin Project	Page
Club Leader Notes	34
Fire Safe Bin Introduction	37
Activity: Investigating Burning	41
Activity: Fire Extinguisher	44
Bin Design	46
K'Nex Fire Engine Challenge	49

Note: This project gets club members investigating a problem that occurs in the environment. To get the most out of this project, take time before you start the project to organise community visits, help from the fire service etc.

SPACE TRAVEL

Focus: SPACE SHUTTLE

K'NEX SPACE SHUTTLE CHALLENGE

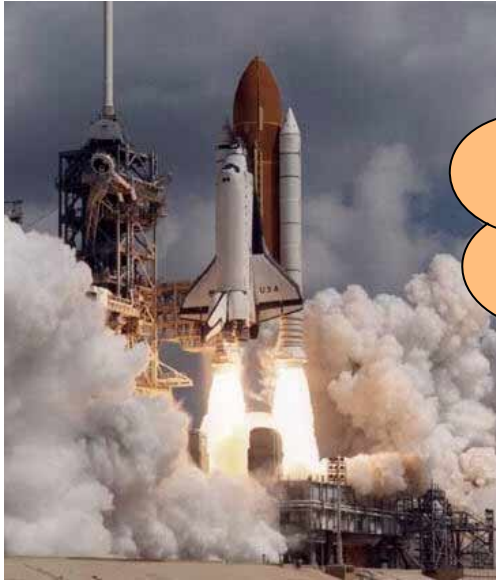

Rockets are used to gain enough speed to break earth's gravity and get into space. Once in orbit, and even during ascent, portions of the rocket are jettisoned (used up and broken off).

The space shuttle is made of three major components: the orbiter which houses the crew; a large external fuel tank that holds fuel for the main engines; and two solid rocket boosters.

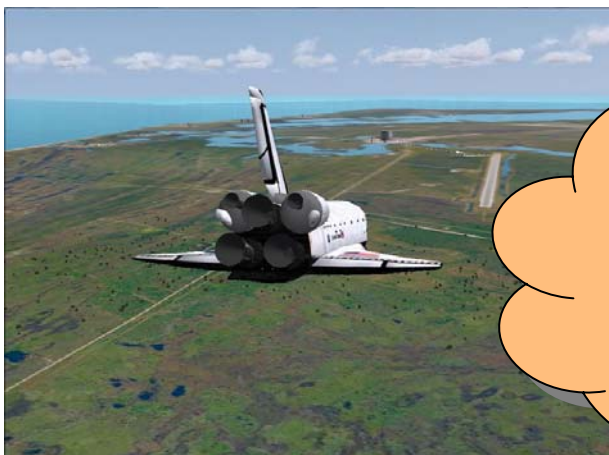
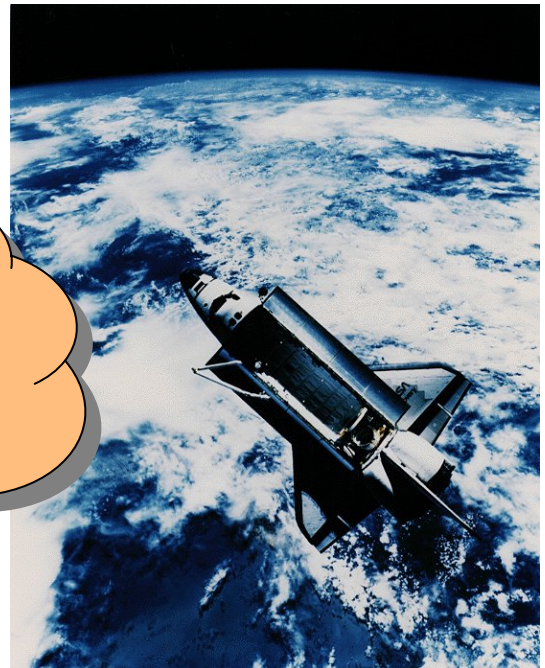

The Shuttle is designed to leave earth's atmosphere like a rocket, but be able to re-enter and fly to its target as a plane. This is a big improvement on using Apollo pods to re-enter, as splashing down in these was very risky.

SPACE TRAVEL

Focus: SPACE SHUTTLE

K'NEX SPACE SHUTTLE CHALLENGE

Your Mission: Design and build a space shuttle orbiter to take a satellite into space using K'Nex.



Design specifications

Your design must have:

- wings and a tail so your shuttle will be able to fly
- an aerodynamically designed nose so the shuttle can cut through the earth's atmosphere
- a compartment where the crew will sit and control the shuttle
- a large cargo section with opening doors big enough to release a satellite through

Remember to design before you build!

You must start the challenge by drawing some of your ideas before you start to build. Try to quickly think of several different ideas before choosing the one you will actually build, as your first idea isn't always your best.

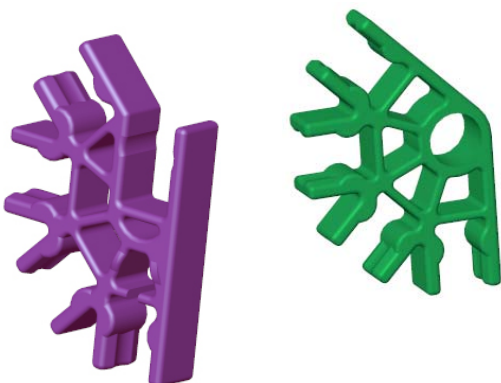
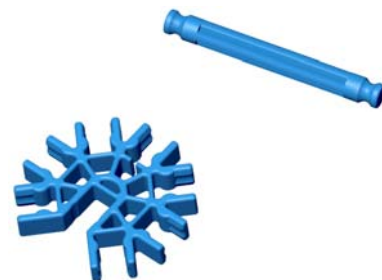

Things to Think Of

1. What K'Nex pieces have you been given?
2. How will you use them in your shuttle design?
3. Are smaller rods with more connectors better than long rods with less connectors?
4. What extra details can you add to your shuttle to make it the winning design?

GOOD LUCK!

WHEELS IN MOTION

Focus: BUGGIES

BASIC BUGGY

Joining two axles with a piece of card can make the simplest buggy. However you will need to add other materials to make the buggy stronger or to help it travel further.

Equipment:

Wooden dowel
Wheels
Card
Scissors
Sticky tape

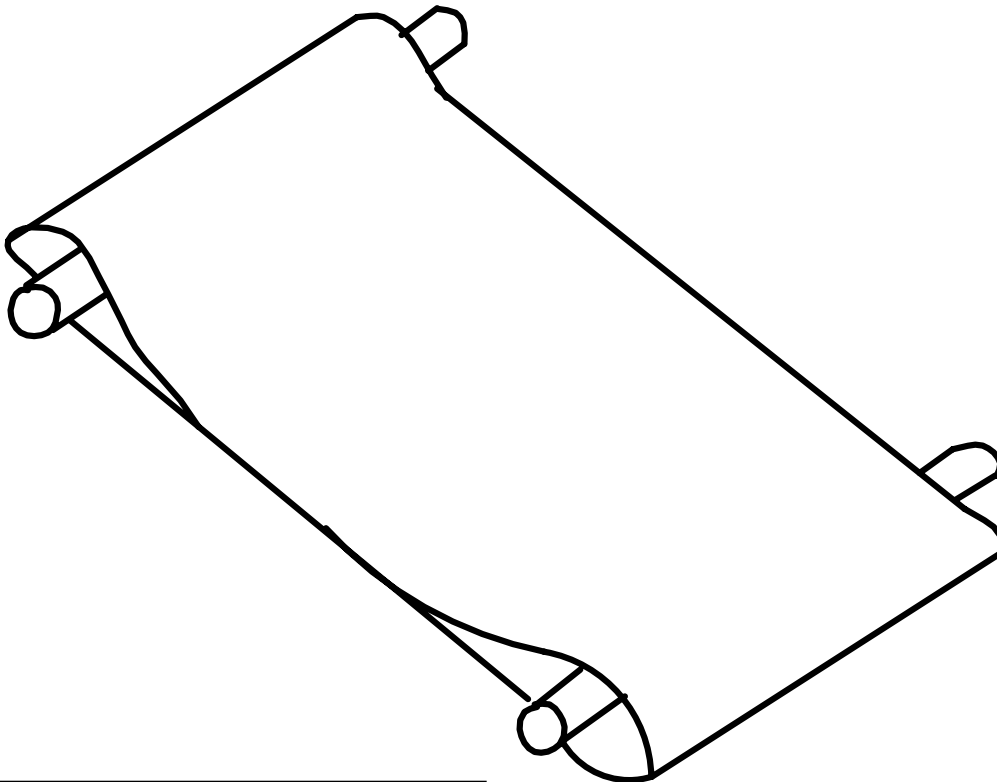

Wrap a strip of card around the pieces of wooden dowel. Leave enough room for the dowel to turn freely and stick the card down.

Attach wheels to the ends of the dowel ensuring that the dowel is a tight fit.

WHEELS IN MOTION

Focus: BUGGIES

BASIC BUGGY

Roll your buggy down a slope and measure how far it travels. Experiment with different lengths of chassis or different widths of axle.

Now you have made a basic buggy, find different ways to improve it.

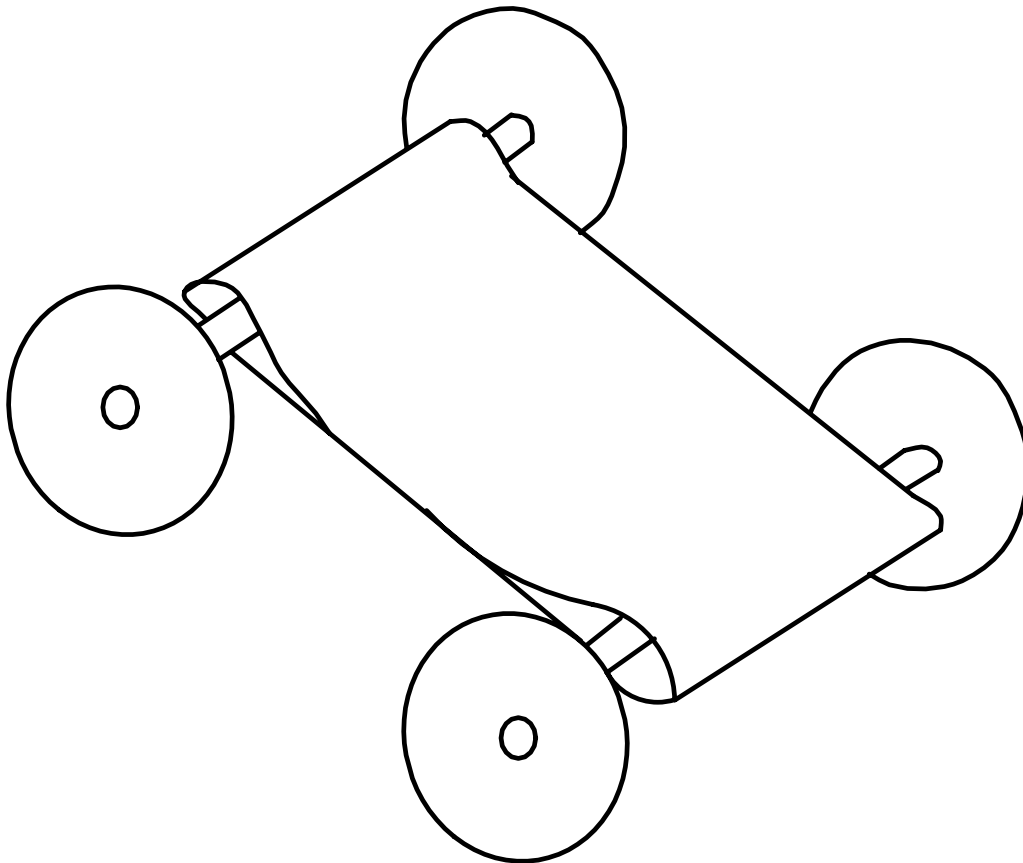

You will create less friction if you can stop the axles rubbing on the card. Find an axle holder - either a straw or a piece of tubing; the barrel of a felt pen makes a good axle holder, can you find different axle holders?

WHEELS IN MOTION

Focus: BUGGIES

'TOOBZ' GRANDSTAND

Your Mission: Design and build a section of grandstand for your buggy race track using drinking straws and a 'Toobz' tool.

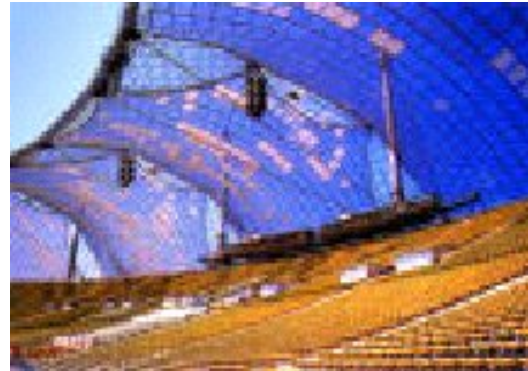

Design specifications

Your grandstand must have at least 2 tiers of seating.

Think about also including:

- Steps to get to the upper tier
- A roof
- Flag poles

Railings along the front row of seats in each tier.



Remember to design before you build!

You must start the challenge by drawing some of your ideas before you start to build. Try to quickly think of several different ideas before choosing the one you will actually build, as your first idea isn't always your best.



GOOD LUCK!

WHEELS IN MOTION

Focus: BUGGIES

ELASTIC BAND POWER

Make a frame for your buggy from square section wood. Either drill holes through to hold the axles or attach axle holders to the frame. Make sure the axle holes or holders are parallel and level with each other to ensure that the buggy runs freely.

Equipment:

Square strip wood
Wheels
5mm dowel
5.5mm drill
or axle holders
Wide elastic band

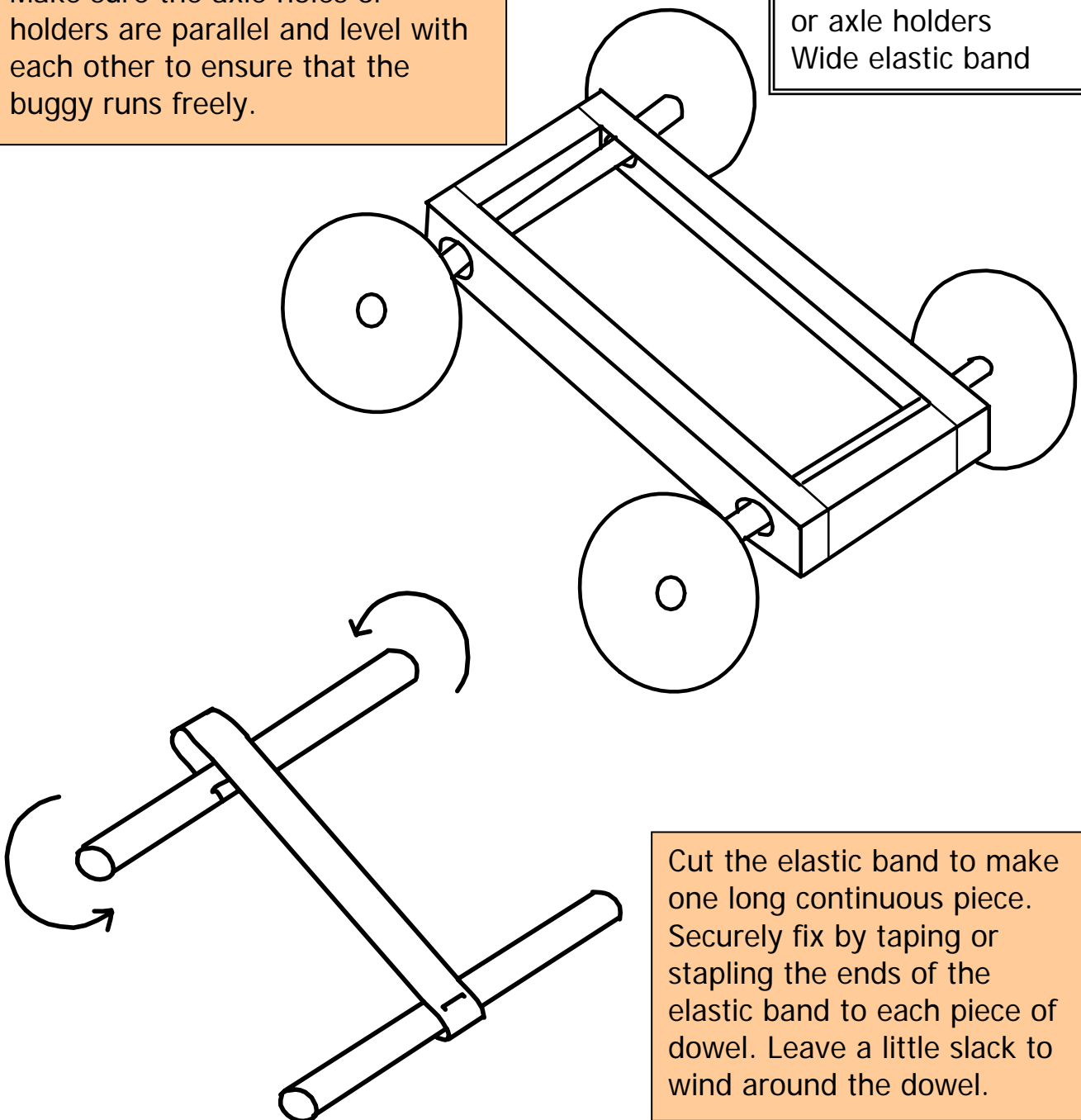

Cut the elastic band to make one long continuous piece. Securely fix by taping or stapling the ends of the elastic band to each piece of dowel. Leave a little slack to wind around the dowel.

WHEELS IN MOTION

Focus: BUGGIES

ELASTIC BAND POWER

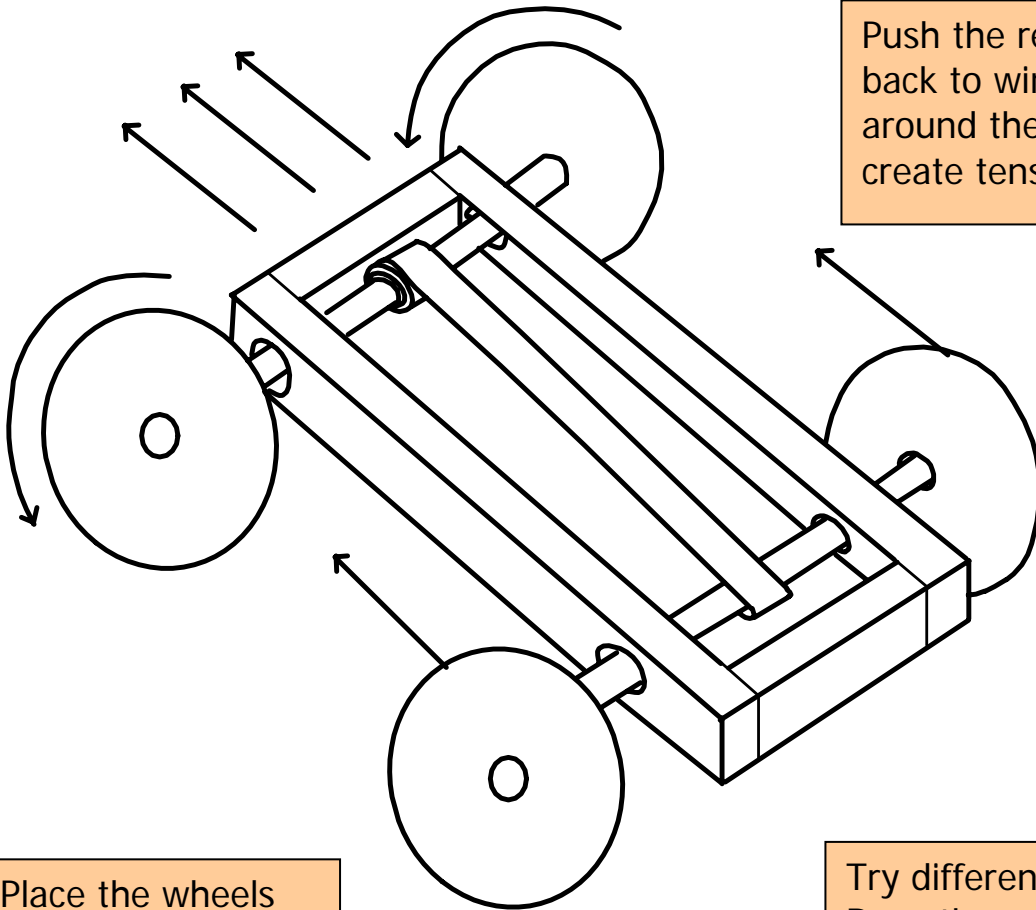

Push the rear wheels back to wind the band around the axle and create tension.

Place the wheels on a surface and let go to release the energy stored in the band. The buggy should speed forwards.

Try different surfaces. Does the car go further on some surfaces than others?

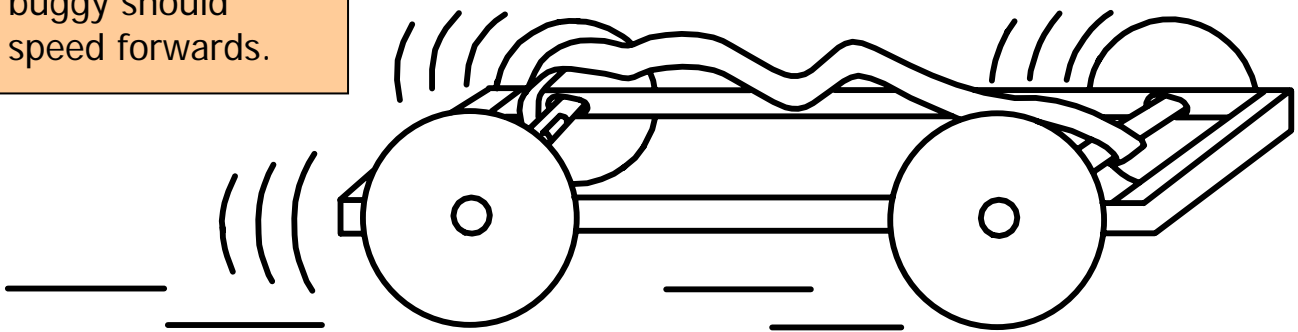

Design some bodywork for the buggy using drinking straws, a 'Toobz' tool and paper. Organise a drag race with your friends.